

# TAG<sup>®</sup>-5000

WIRELESS PHASER

*and ACCESSORIES*

Operating & Instruction Manual



**HD ELECTRIC COMPANY**

1475 LAKESIDE DRIVE • WAUKEGAN, ILLINOIS 60085 U.S.A.  
PHONE 847.473.4980 • FAX 847.473.4981 • website: [www.HDElectricCompany.com](http://www.HDElectricCompany.com)

# TAG<sup>®</sup>-5000

WIRELESS PHASER

***and ACCESSORIES***

## Operating & Instruction Manual

|                              |     |
|------------------------------|-----|
| DESCRIPTION .....            | 3   |
| SAFETY .....                 | 3-4 |
| HOW TO USE IT .....          | 4-6 |
| SITUATIONS TO AVOID .....    | 7   |
| BATTERY REPLACEMENT .....    | 7   |
| ACCESSORIES .....            | 8-9 |
| SPECIFICATIONS .....         | 10  |
| MAINTENANCE AND CARE .....   | 10  |
| WARRANTY AND LIABILITY ..... | 12  |

## DESCRIPTION

The TAG-5000 Wireless Phaser is a two unit system used to verify an in-phase condition between any two phases of a three phase power system. The TAG-5000 can be used anywhere a typical phasing voltmeter is used and many places where phasing voltmeters cannot be used due to distance or higher voltages. The standard TAG-5000 is supplied with a carrying case, the receiver and transmitter units and two probes (one hook and one "Y" probe) designed for overhead use. The probes are interchangeable between the two units, and can be selected based on preferred placement and company procedures. Each unit has a universal spline hotstick attachment built into the housing. Extension hotsticks should always be used. Both units are powered by 9V alkaline batteries. Optional underground probes are available for underground or pad mount applications or for any application where the TAG-5000 will be used in close proximity to grounded conductors or surfaces.

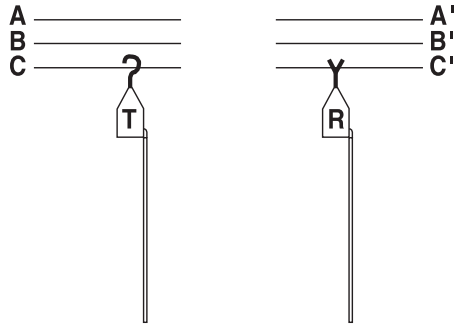

**WIRELESS PHASING SET**

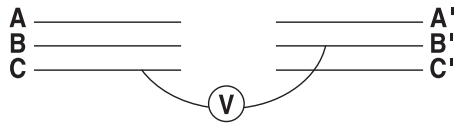

**CONVENTIONAL PHASING EQUIPMENT**

Each unit has a universal spline hotstick attachment built into the housing. Extension hotsticks should always be used. Both units are powered by 9V alkaline batteries. Optional underground probes are available for underground or pad mount applications or for any application where the TAG-5000 will be used in close proximity to grounded conductors or surfaces.

## SAFETY

- Only trained, professional operating personnel should use the TAG-5000. The voltages this instrument operates at are dangerous and lethal. Severe injury or death can occur if improperly used.
- Risk of electrocution is inherent in or around high voltage.
- Always use proper high voltage procedures, including personal protective equipment, when working near or around high voltage equipment or conductors.
- Do not use on voltages less than the minimum voltage on the device label and do not exceed the TAG-5000 maximum voltage rating of 230kV line-to-line.
- Always assemble the TAG-5000 with the proper contact probe for your application.

- Always use a hotstick with length appropriate for the voltage being measured per your company and OSHA published requirements.
- Do not touch the TAG-5000 during measurements. The TAG-5000 housing should be considered to be at the same voltage as the conductor under test.
- Prior to using, inspect the instrument for cleanliness, any physical damage and check for proper working order by pressing and holding the All-Check™ buttons on each unit. Do not proceed if the units are not operating properly.
- Never allow another high voltage or grounded conductor to contact the instrument during use. Keep the TAG-5000 housing free and clear of all structures at all times.
- If the TAG-5000 does not indicate the presence of voltage it does not mean that the line is dead or grounded. The TAG-5000 may not indicate voltages below the minimum voltage on the device label. Always use proper grounding procedures.
- The TAG-5000 units are direct contact devices. The metal portion of the TAG-5000 probe must contact the metal conductor to be tested. Voltage and phasing indication on insulated conductors such as tree wire or spacer wire will be unreliable.
- The TAG-5000 is sensitive to geometry. Read and understand this entire manual before using the TAG-5000.
- The TAG-5000 is for three phase 50/60Hz systems only. It does not work on other poly-phase systems.

**Do not use the TAG-5000 to phase or synchronize connections to generators**

## HOW TO USE IT

### Testing

Install the probes on both the transmitter and receiver. For overhead applications the hook probe is generally placed on the transmitter while the Y probe is placed on the receiver. Test the units by holding one in each hand and pressing and holding the All-Check button on each unit. The transmitter will begin a series of beeps and flashing lights lasting about 5 seconds. The receiver will emit a single short beep. When the transmitter stops beeping, it will start transmitting a radio signal to the receiver and the receiver will respond with a series of beeps and flashing lights indicating proper reception of the signal from the transmitter.



If the transmitter or receiver do not operate properly, replace the batteries in both units and repeat the test. Do not use the TAG-5000 until it successfully passes this test. Install the TAG-5000 transmitter and receiver on hotsticks with length appropriate for the voltage to be tested by way of the built-in universal spline, making certain it is securely attached. The transmitter and receiver can also be tested on an energized line within the voltage range on the device label by simply placing each unit on the same line. The transmitter should begin beeping as described above and when it stops the receiver should start a steady tone indicating an in-phase condition.

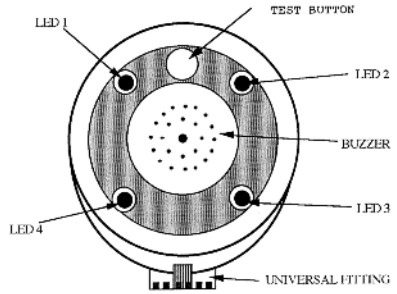

**VIEW OF TRANSMITTER**

**Phasing**

Many companies have their own operating rules concerning phasing in conductors at a switch point. The following procedure is intended to be one example of proper use of the TAG-5000 but is not the only acceptable procedure.

1) Place the transmitter on each of the 6 conductors to verify the presence of voltage on each conductor. The transmitter will begin beeping when voltage is detected. On higher voltage systems the transmitter may begin beeping before the conductor is contacted, but always make sure that metal to metal contact is made between the transmitter probe and the live conductor.

2) Place the transmitter on the first conductor to be phased. When the transmitter stops beeping, one light remains on indicating the unit is transmitting.

3) Place the receiver on the proper conductor on the opposite side of the open point (e.g. switch) to determine if the two conductors are in-phase. When placed on an energized conductor the unit will beep once when voltage is detected and one LED light of the receiver will turn on to signal that the unit is operating in the receive mode.

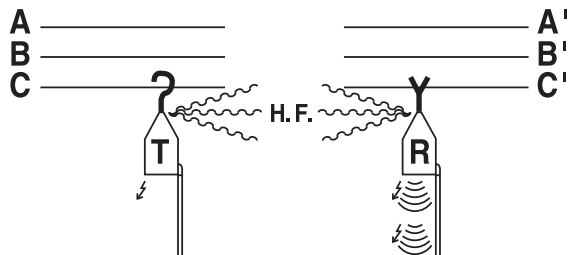
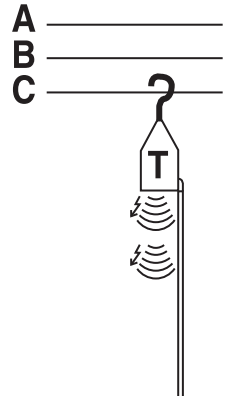

**On higher voltage systems the receiver may beep before the conductor is contacted, but always make sure that metal to metal contact is made between the receiver probe and the live conductor.**

If the two conductors are in-phase the other three receiver lights will turn on and the unit will emit a steady tone. The TAG-5000 receiver is signaling that this phase of the system is in-phase with the transmitter.

If the conductors are out of phase, the receiver will supply a brief burst of all lights and a single short beep of the beeper but will not emit a steady tone.

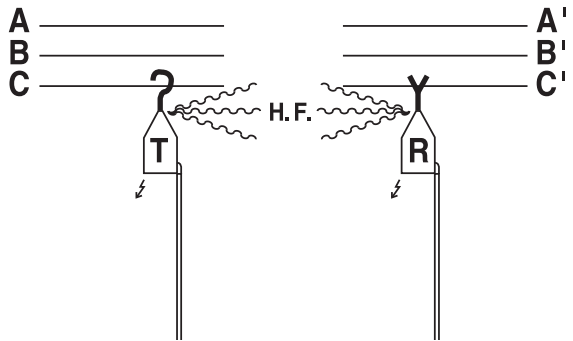

4) Test all phases for an in-phase indication from the TAG-5000 to make certain that each phase is lined up correctly prior to closing in a switch. When an in-phase condition is shown for all three phases, the phasing operation is complete.

5) Test the TAG-5000 units using the procedures in the Testing section above to make certain that the units operated properly throughout the phasing procedure. If the testing procedure indicates that the units are not operating properly, DO NOT ASSUME that the phasing procedure just completed is correct. Remove the TAG-5000 units from service and re-phase the line using different phasing equipment.

**WARNING:** Use of the TAG-5000 units at a distance greater than allowed on page 11 may not provide proper operation due to loss of radio signal between the two units. Also, mobile communication devices may cause interference in transmission of the radio signal and can cause false signals. Care should be taken in operating other radio generating devices near the TAG-5000 units during operation.

## SITUATIONS TO AVOID

Electrical field interference can affect the operation of the TAG-5000. For best performance avoid the following:

- 1. 90° CORNER CONFIGURATIONS:** Position the TAG-5000 at least three feet (1 meter) away from any inside or outside corner. Any 90° inside corner configuration may cause field cancellation, causing the TAG-5000 not to operate correctly.
- 2. SAME PHASE INTERFERENCE:** When two conductors of the same phase are in close proximity to one another, the field generated could shield the TAG-5000, causing it to not operate. Reposition the TAG-5000 to areas which will remove it from these situations.

## BATTERY REPLACEMENT

The battery is tested each time the All-Check button is depressed and battery replacement should be the first step taken if the All-Check button does not provide the signal described in the Testing section. The battery in the transmitter and receiver should be replaced at the same time to ensure proper operation. Change out the batteries of the units by performing the following steps (see Figure 1 - TAG Components on the next page):

- 1) Remove the probe and the retaining nut from the top of the units.
- 2) Push out the electronic housing from within the polycarbonate casing by using the probe. Press firmly and slowly to remove the housing since the gaskets that protect the unit will provide resistance.
- 3) Carefully remove the metal shield from the electronic housing to get access to the battery. Make certain that the ground lead which is connected from the PC board to the inside of the metal shield is intact. If it is broken, or breaks, return the TAG-5000 to HD Electric Company for repair.
- 4) Remove the existing battery from its compartment by gently prying the battery from the bottom of the unit. Take care not to damage the circuit board that the battery is mounted on.
- 5) Replace the old battery with a fresh alkaline 9V DC battery, Duracell #MN1604 or equivalent. Again, take care in installing the new battery not to damage the circuit board. In addition, make certain that polarity is correct when the battery is installed by matching the plus of the battery to the plus sign indicated on the battery holder.
- 6) Replace the metal shield, place the housing back in the casing, and re-install the retaining nut and probe.
- 7) Press the All-Check button to confirm that the new battery is allowing the units to operate correctly.

**Figure 1 - TAG Components**

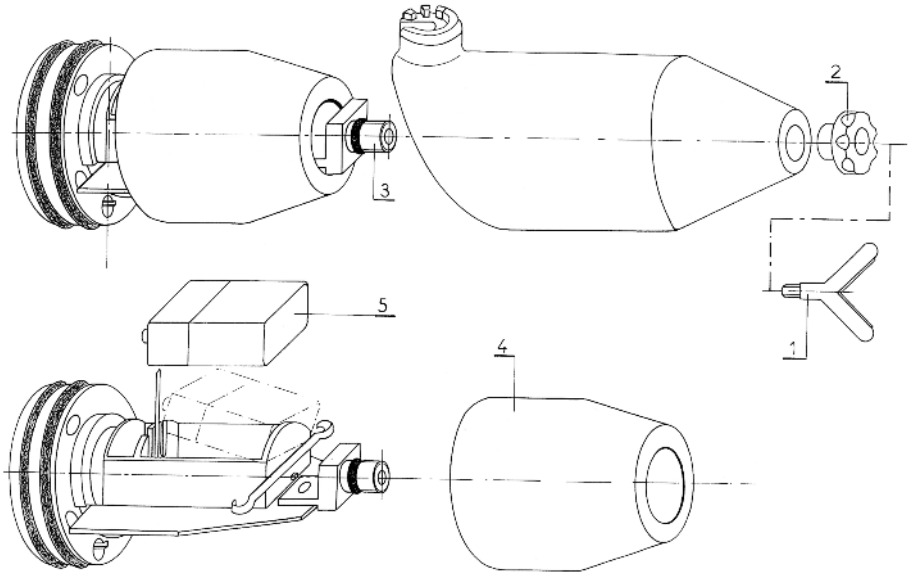

1 - "Y" Probe, 2 - Retaining Nut, 3 - Electronic Housing, 4 - Metal Shield, 5 - Battery

## ACCESSORIES

### **IEP-UD/C Underground Bushing Probe**

The IEP-UD/C Underground Bushing Probe is designed for direct insertion into exposed 15, 25 or 35kV loadbreak bushings (after connecting elbows have been removed and properly stored). The probe must be inserted directly into the bushing and remain free and clear of all surrounding surfaces. It is rated for use up to 21kV phase-to-ground. This probe should also be used in metal clad switchgear or any other applications where grounded or other live conductors may be in close proximity to the conductor being tested.

#### **TO ASSEMBLE THE IEP-UD/C PROBE ON THE TAG-5000:**

1. Inspect the IEP-UD/C probe for any mechanical defects and make certain it is clean and dry.
2. Remove the overhead probe and screw the IEP-UD/C onto each TAG-5000. Make certain it is snug by hand tightening, but **DO NOT OVERTIGHTEN**.
3. Test the fully assembled TAG-5000 on a known voltage source prior to using.



## IEP-EA/C UNDERGROUND ELBOW PROBE

The IEP-EA/C Underground Elbow Probe is designed for insertion onto 15, 25 and 35kV loadbreak elbow probes. The probe must be inserted directly onto the elbow probe and remain free and clear of all surrounding surfaces. It is rated for use up to 21kV phase to ground.

### TO ASSEMBLE THE IEP PROBE ON THE TAG-5000:

1. Inspect the IEP probe for any mechanical defects and make certain it is clean and dry.
2. Remove the overhead probe and screw the IEP onto each TAG-5000. Make certain it is snug by hand tightening, but DO NOT OVERTIGHTEN.
3. Test the fully assembled TAG-5000 on a known voltage source prior to use.



## OTHER ACCESSORIES

Adapter for Shotgun Stick (HSA-2500)



## HOTSTICKS

A range of hotsticks are available in lengths starting at 4'. Contact HD Electric for more details.

### HOTSTICKS



## SPECIFICATIONS

**MODEL NUMBER:** TAG-5000

**OPERATING VOLTAGE RANGE:** 4 - 230kV line-to-line

**OPERATING FREQUENCY AND PHASING:** 50/60Hz

In phase indication for phase angle shift  $\leq 10^\circ$

No in phase indication for phase angle  $\geq 30^\circ$

**TRANSMISSION:** Radio frequency: 433.9MHz

Transmission power: < 10mW

Range: >33 ft. through the air, up to 3000 ft. along overhead conductors and underground cables with polyethylene insulation; range is substantially reduced in underground conductors with rubber insulation.

**OPERATING TEMPERATURE RANGE:** -20F to +120F

**WEIGHT:** 1.2 lb. each unit with overhead probe

## MAINTENANCE AND CARE

**BATTERY** - The batteries require checking prior to each use. Use the All-Check button to confirm proper operation. The All-Check button tests the battery voltage in addition to the electronic circuitry, so it is a good test of battery strength. If the All-Check button does not cause the lights to flash and the alarm to sound, replace the batteries with alkaline or lithium types only.

**STORAGE** - It is recommended for protection of the TAG-5000 that you always store it and its accessories in the carrying case provided.

**CLEANLINESS** - The molded housings are very rugged but should be kept clean and free of dirt, grease and any other foreign materials. If the housings' surface integrity has been compromised in any way, remove from service and return to factory for repair or replacement.

**WARNING:** DO NOT USE SOLVENTS OF ANY KIND FOR CLEANING.

**DAMAGE** - If you suspect any mechanical or electrical damage, do not use the TAG-5000 and arrange for repair by returning to the factory.

**CALIBRATION & TESTING** - Regular calibration of the TAG-5000 is not required. There is no accessible calibration adjustment.

**SERVICE** - Return to HD Electric Company for service.



## LIMITED WARRANTY AND LIMITATION OF LIABILITY

This warranty applies to all products sold by HD Electric Company (the "Products"); provided, however, that the term Products does not include any third party products purchased through HD Electric Company, for which no warranties are made (the "Third Party Products"). Third Party Products may be subject to a separate manufacturer's warranty; [should you have any question regarding whether a separate warranty applies, please contact HD Electric Company].

NOTICE: READ THIS LIMITATION OF WARRANTY AND LIABILITY BEFORE BUYING OR USING THE PRODUCTS CONTAINED HEREIN.

It is impossible to eliminate all risks associated with the use of the Products. Risks of serious injury or death, including risks associated with electrocution, arcing and thermal burns, are inherent in work in and around energized electrical systems. Such risks arise from the wide variety of electrical systems and equipment to which Products may be applied, the manner of use or application, weather and environmental conditions or other unknown factors, all of which are beyond the control of HD Electric Company.

HD Electric Company does not agree to be an insurer of these risks.

WHEN YOU BUY OR USE THESE PRODUCTS, YOU AGREE TO ACCEPT THESE RISKS.

HD Electric Company warrants to the original purchaser that the Products (excluding any third party products purchased through HD Electric Company, for which no warranties are made) will be free from defects in material and workmanship, under normal use and regular service, and preventative maintenance for a period of one (1) year from the date of shipment (the "Warranty Period"). Should any failure to conform with this warranty be found during the Warranty Period, you must notify HD Electric Company of your claim within thirty (30) days of discovery, and within the Warranty Period. Your failure to give notice of claims of breach of warranty within the Warranty Period shall be deemed an absolute and unconditional waiver of claims for such defects. HD Electric Company will have no responsibility to honor claims received after the date the applicable Warranty Period expires.

Upon notice of your claim, HD Electric Company will provide a return authorization number, and further instructions on how to return the product for service. You must follow HD Electric Company's instruction. You are responsible for all Product removal, handling, re-installation, and shipping (both to and from HD Electric Company). Products returned for repair, as well as repaired or replacement Products shall be sent postage / freight prepaid. After receipt of a product which HD Electric Company determines is defective, HD Electric will, at its option, either (1) repair (or authorize the repair of) the Product or (2) replace the Product, subject to the following: The Products are made using parts sourced from a variety of manufacturers. Due to the rapidly changing technology environment, parts may become obsolete / unavailable over time (end of life). In the event that a Product cannot be repaired or replaced due to unavailability of parts, HD Electric Company will use commercially reasonable efforts to obtain substitute parts or conduct work around design, but cannot guarantee its ability to do so.

Items not found defective will be returned at your expense, or failing receipt of instruction from you on return of such items within five (5) business days of our notice to you that the product is not defective, HD Electric may dispose of the product at its discretion and with no liability to you. HD Electric Company's determination of defects is final. Products repaired or replaced during the Warranty Period shall be covered by the foregoing warranties for the remainder of the original Warranty Period or ninety (90) days from the date of delivery of the repaired or replaced Products, whichever is longer.

### LIMITATIONS:

This warranty is void in the event of misuse, alteration, faulty installation, or misapplication of the product. This warranty does not cover failure of product or components due to any ACT OF NATURE; lightning, floods, hurricanes, tornadoes or any other such catastrophic events.

HD Electric Company does not warrant any third party products or associated hardware or their performance or suitability for use and application. Such items are provided "as-is".

All repairs must be authorized by HD Electric Company. Unauthorized repairs will not be reimbursed under any circumstances.

HD Electric Company is not required to make replacement or loaner equipment available while Products are being repaired or replaced, or to compensate you for any in/out labor charges or expenses associated with removal, handling or re-installation of the Products.

TO THE MAXIMUM EXTENT PERMITTED BY LAW, THIS WARRANTY AND THE REMEDIES SET FORTH ABOVE ARE EXCLUSIVE AND IN LIEU OF ALL OTHER WARRANTIES, REMEDIES AND CONDITIONS, WHETHER ORAL OR WRITTEN, EXPRESS OR IMPLIED. HD ELECTRIC EXPRESSLY DISCLAIMS ALL OTHER WARRANTIES OF ANY KIND, EXPRESS OR IMPLIED, INCLUDING WITHOUT LIMITATION IMPLIED WARRANTIES OF FITNESS FOR A PARTICULAR PURPOSE, MERCHANTABILITY AND NON-INFRINGEMENT.

IN NO EVENT SHALL HD ELECTRIC COMPANY BE LIABLE FOR ANY INCIDENTAL, CONSEQUENTIAL OR SPECIAL DAMAGES RESULTING FROM THE USE OR HANDLING OF THESE PRODUCTS. THIS SHALL INCLUDE BUT, NOT LIMITED TO, LOST PROFITS OR REVENUE, LOSS OF USE OF THE PRODUCTS, COST OF SUBSTITUTE PRODUCTS, FACILITIES OR SERVICES, OR DOWNTIME.

IN NO EVENT SHALL HD ELECTRIC COMPANY HAVE ANY LIABILITY FOR ANY THIRD PARTY PRODUCTS OR ASSOCIATED HARDWARE, OR CUSTOMER-OWNED SYSTEMS, EQUIPMENT OR SOFTWARE.

HD Electric Company must have prompt notice of any claim so that an immediate product inspection and investigation can be made. Buyer and all users shall promptly notify HD Electric Company of any claims, whether based on contract, negligence, strict liability, or other tort or otherwise be barred from any remedy.

HD Electric Company is committed to ongoing review and improvement of its product lines, and thus reserves the right to modify product design and specifications without notice.

HD Electric Company products are available through HD sales representatives worldwide.

Printed in U.S.A. © HD Electric Company 2011 • Bulletin No. TAG5000 IM-100a